

## 2004 SUSPENSION

### Tires and Wheels - Hummer H2

## SPECIFICATIONS

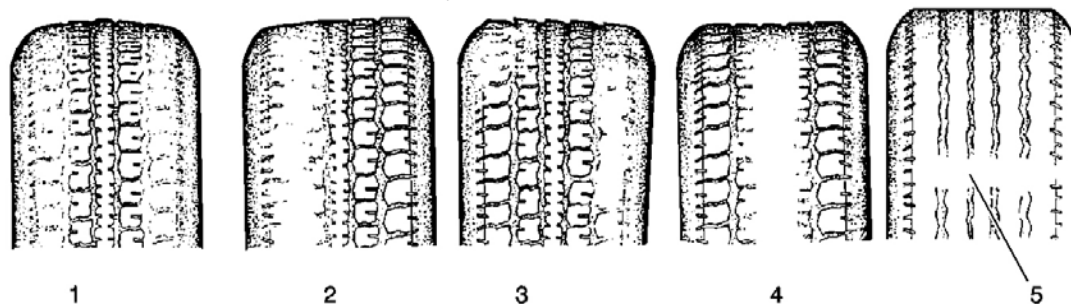
### FASTENER TIGHTENING SPECIFICATIONS

#### Fastener Tightening Specifications

Application	Specification	
	Metric	English
Jack Storage Bracket Screw	25 N.m	18 lb ft
Single Wheel Nuts	190 N.m	140 lb ft
Spare Tire Carrier Retaining Bolt	85 N.m	63 lb ft
Spare Tire Retaining Nut	40 N.m	30 lb ft

## DIAGNOSTIC INFORMATION AND PROCEDURES

### TIRE DIAGNOSIS - IRREGULAR OR PREMATURE WEAR



**Fig. 1: Tire Wear**

Courtesy of GENERAL MOTORS CORP.

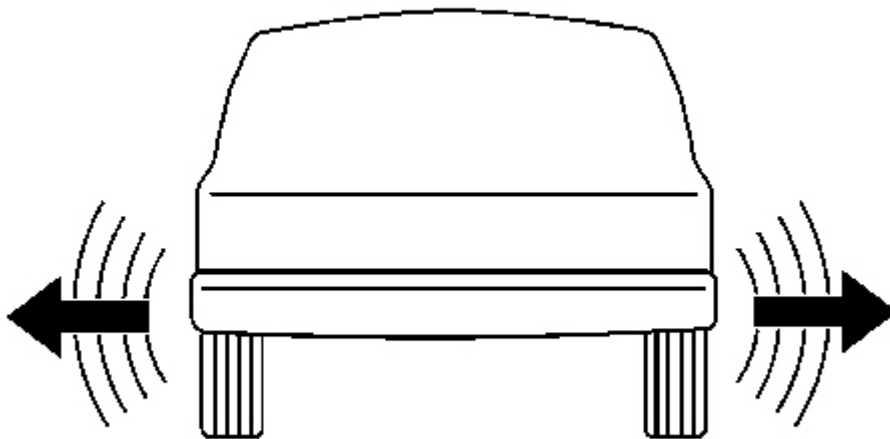
#### Callouts For Fig. 1

Callout	Component Name
1	Under-inflation, Hard Cornering, Lack of Regular Rotation
2	Incorrect Wheel Alignment, Hard Cornering, Lack of Regular Rotation
3	Incorrect Wheel Alignment, Shock Absorber Failure
4	Over-inflation, Heavy Acceleration, Lack of Regular Rotation
5	Normal Wear to the Wear Indicator

#### Inspection Procedure

1. Inspect the front tire wear.
2. Inspect the rear tire wear.
3. Rotate the tires if any of the following conditions exist:
  - The amount of time or mileage since the last tire rotation matches the maintenance schedule.
  - The outer tread blocks are worn more than the middle tread blocks (1).
  - The outer tread blocks are worn more than the inner tread blocks (2).
  - The middle tread blocks are worn more than the outer tread blocks (4).
4. Measure the wheel alignment if any of the following conditions exist:
  - The tread blocks have feathered edges (3).
  - The outer tread blocks are worn more than the inner tread blocks (2).
  - The inner tread blocks are worn more than the outer tread blocks (2).
5. Inspect the struts or the shock absorbers if the tire tread exhibits a cupped appearance (3).

## **TIRE DIAGNOSIS - WADDLE COMPLAINT**



**Fig. 2: Identifying Tire Waddle**  
Courtesy of GENERAL MOTORS CORP.

Tire waddle is a side to side movement at the front of the vehicle and/or the rear of the vehicle. Tire waddle can be caused by the following conditions:

- A steel belt not being straight within the tire
- Excessive lateral runout of the tire

- Excessive lateral runout of the wheel

The tire waddle is most noticeable at a low speed of about 8-48 km/h (5-30 mph). Tire waddle may appear as ride roughness at 80-113 km/h (50-70 mph). Tire waddle may appear as a vibration at 80-113 km/h (50-70 mph).

### **Inspection Procedure**

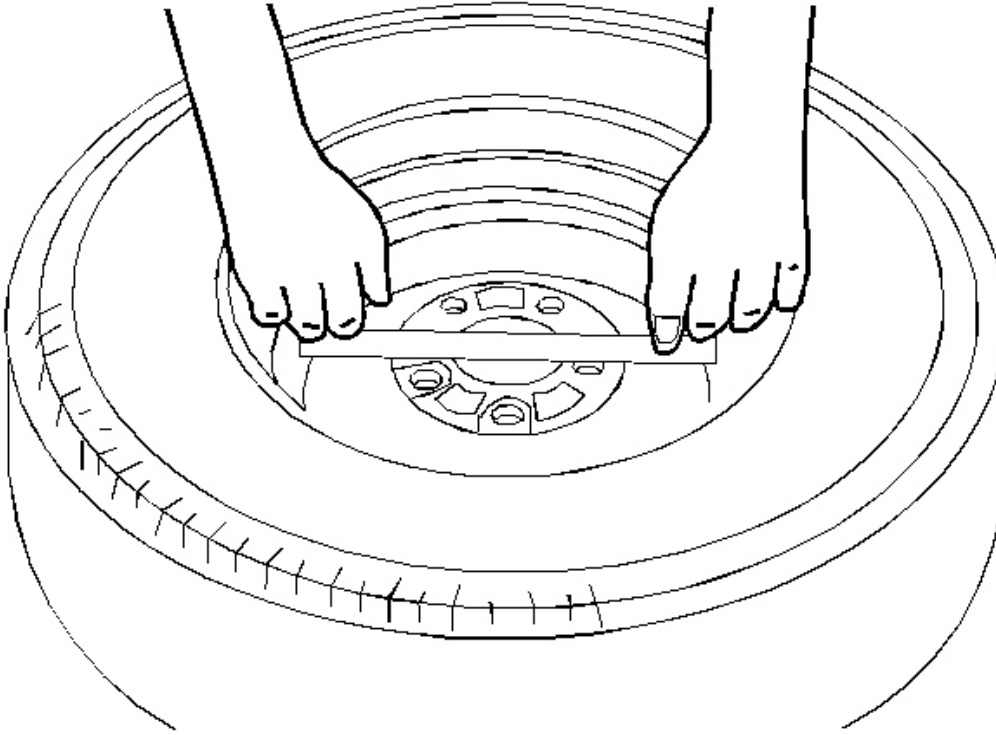
1. Raise and support the vehicle with safety stands. Refer to **Lifting and Jacking the Vehicle** in General Information.

**CAUTION: Wear gloves when inspecting the tires in order to prevent personal injury from steel belts sticking through the tire.**

2. Perform the following preliminary inspection:
  1. Mark the tire with a crayon in order to note the start and the stop position.
  2. Rotate each tire and wheel by hand.
  3. Inspect the tire for bulges or bent wheels. Replace as necessary.
3. Use tire substitution in order to identify the faulty tire. Perform the following steps for a tire substitution check:
  1. Use a comparable tire in order to replace each tire, one at a time.
  2. Test drive the vehicle.
  3. If the problem is tire or wheel related, you will eliminate the problem when you remove the faulty tire from the vehicle.

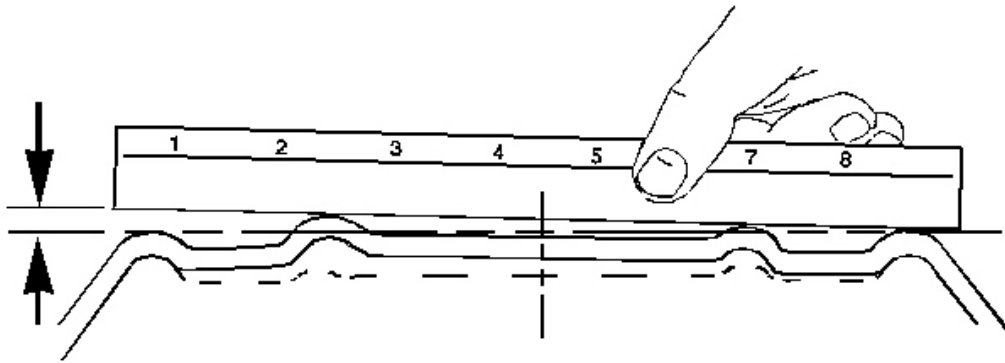
### **WHEEL MOUNTING SURFACE CHECK**

Replace any wheels that are bent or dented, or have excessive lateral or radial runout. Wheels with runout greater than specified may cause objectionable vibrations.



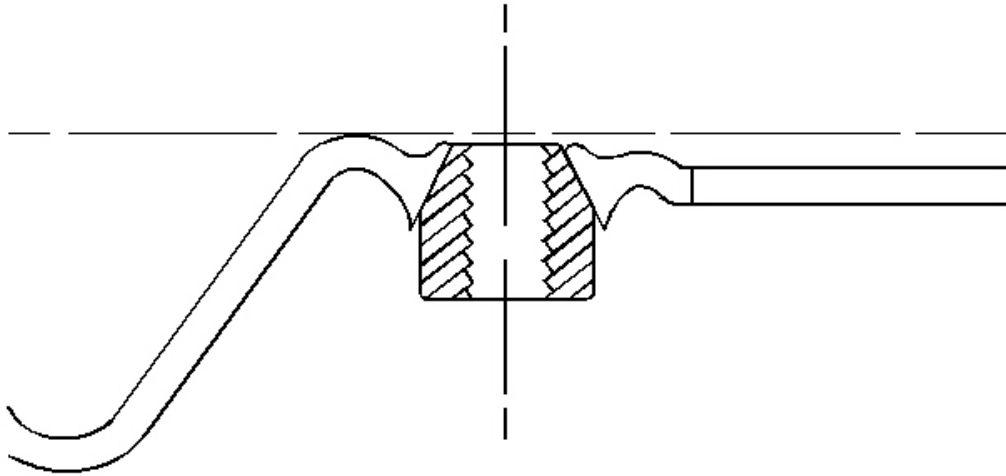
**Fig. 3: Wheel Mounting Surface Check**  
Courtesy of GENERAL MOTORS CORP.

1. Use a straight edge 203-229 mm (8-9 in) long. Place the straight edge on the wheel inboard mounting surface. Try to rock the straightedge up and down within the mounting surface.



**Fig. 4: Inspecting Wheel Mounting Surface**  
Courtesy of GENERAL MOTORS CORP.

2. Repeat this procedure on at least 3-4 different positions on the inboard mounting surface.
  - The outer ring of the mounting surface normally is raised above everything inside the mounting surface.
  - The mounting surface will be raised above the outer ring if the wheel mounting surface has been bent on a tire changer.
  - If you can rock the straight edge, the mounting surface is bent and you must replace the wheel.



**Fig. 5: Inspecting Mounting Wheel/Nut Holes**  
Courtesy of GENERAL MOTORS CORP.

3. Inspect the mounting wheel/nut holes for damage caused from over-torquing the wheel/nuts. Inspect for collapsed wheel/nut bosses. Inspect for cracked wheel bosses.

**NOTE:** The use of non-GM original equipment wheels may cause:

- Damage to the wheel bearing, the wheel fasteners and the wheel
- Tire damage caused by the modified clearance to the adjacent vehicle components
- Adverse vehicle steering stability caused by the modified scrub radius
- Damage to the vehicle caused by the modified ground clearance
- Speedometer and odometer inaccuracy

**IMPORTANT:** Replacement wheels must be equivalent to the original equipment wheels in the following ways:

- The load capacity
- The wheel diameter
- The rim width
- The wheel offset
- The mounting configuration

- **A wheel of the incorrect size or type may affect the following conditions:**

- **Wheel and hub-bearing life**
- **Brake cooling**
- **Speedometer/odometer calibration**
- **Vehicle ground clearance**
- **Tire clearance to the body and the chassis**

4. Replace the wheel if the wheel is bent.
5. Replace the wheel if the wheel/nut boss area is cracked.

Identify steel wheels with a 2 or 3-letter code stamped into the rim near the valve stem. Aluminum wheels have the code, the part number, and the manufacturer identification cast into the back side of the wheel.

## **RADIAL TIRE LEAD/PULL CORRECTION**

### **Radial Tire Lead/Pull Correction**

<b>Step</b>	<b>Action</b>	<b>Yes</b>	<b>No</b>
DEFINITION: Lead/pull is the deviation of the vehicle from a straight path on a level road with no pressure on the steering wheel.			
1	Did you perform the Vehicle Leads/Pull diagnostic table in Suspension General Diagnosis?	Go to <b>Step 2</b>	Go to <b>Vehicle Leads/Pulls</b> in Suspension General Diagnosis
2	Road test the vehicle to verify the complaint. Select a smooth level surface to perform the test. Does the condition exist?	Go to <b>Step 3</b>	System OK
3	1. Cross-switch the front tire/wheel assemblies. Refer to <b><u>Tire and Wheel Removal and Installation</u></b> . 2. Road test the vehicle on a smooth level surface.  Does the vehicle still lead/pull?	Go to <b>Step 4</b>	System OK
4	Does the vehicle lead/pull in the opposite direction?	Go to <b>Step 5</b>	Go to <b><u>Measuring Wheel Alignment</u></b> in Wheel Alignment
5	1. Cross-switch the left front tire/wheel assembly with the left rear tire/wheel assembly. Refer to <b><u>Tire and Wheel Removal and Installation</u></b> . 2. Road test the vehicle on a smooth level		

	surface. Does the vehicle still lead/pull?	Go to <b>Step 6</b>	Go to <b>Step 7</b>
6	1. Cross-switch the right front tire/wheel assembly with the right rear tire/wheel assembly. Refer to <b><u>Tire and Wheel Removal and Installation</u></b> . 2. Road test the vehicle on a smooth level surface. Does the vehicle still lead/pull?	Go to <b>Measuring Wheel Alignment</b> in Wheel Alignment	Go to <b>Step 8</b>
7	Replace the left rear tire. Refer to <b><u>Tire Mounting and Dismounting</u></b> . Is the repair complete?	Go to <b>Step 9</b>	-
8	Replace the right rear tire. Refer to <b><u>Tire Mounting and Dismounting</u></b> . Is the repair complete?	Go to <b>Step 9</b>	-
9	Verify proper vehicle operation. Does the original condition still exist?	Go to <b>Step 1</b>	System OK

## REPAIR INSTRUCTIONS

### ALUMINUM WHEEL POROSITY REPAIR

1. Remove the tire and wheel. Refer to **Tire and Wheel Removal and Installation** .
2. Inflate the tire to the manufactures specified pressure as stated on the tire.
3. Submerge the tire/wheel into a water bath in order to locate the leak.
4. Inscribe a mark on the wheel in order to indicate the leak areas.
5. Inscribe a mark on the tire at the valve stem in order to Indicate the orientation of the tire to the wheel.
6. Remove the tire from the wheel. Refer to **Tire Mounting and Dismounting** .

**IMPORTANT: Do not damage the exterior surface of the wheel.**

7. Use number 80 grit sandpaper to scuff the inside of the rim surface at the leak area.
8. Use general purpose cleaner such as 3M(R), P/N 08984 or equivalent, to clean the leak area.
9. Apply 3 mm (0.12 in) thick layer of adhesive/sealant, GM P/N 12378478 (Canadian P/N 88900041) or equivalent, to the leak area.
10. Allow for the adhesive/sealant to dry.
11. Align the inscribed mark on the tire with the valve stem on the wheel.
12. Install the tire to the wheel. Refer to **Tire Mounting and Dismounting** .
13. Inflate the tire to the manufactures specified pressure as stated on the tire.
14. Submerge the tire/wheel into a water bath in order ensure the leak is sealed.



15. Balance the tire and wheel. Refer to **Tire and Wheel Assembly Balancing - Off-Vehicle** in Vibration Diagnosis and Correction.
16. Install the tire and wheel. Refer to **Tire and Wheel Removal and Installation** .
17. Lower the vehicle.

## **ALUMINUM WHEEL REFINISHING**

### **Aluminum Wheel Refinishing Guidelines**

**CAUTION:** To avoid personal injury when exposed to plastic media blast, hand and/or lathe sanding dust, primer, color coat, and clearcoat, you must work in a properly ventilated area, wearing an approved respirator, eye protection, earplugs and protective gloves and clothing.

### **Evaluating Damage**

- IMPORTANT:**
- Inspect the wheel for corrosion, scrapes, gouges, etc. Damage **MUST NOT** be deeper than what can be sanded or polished off.
  - Inspect the wheel for cracks. If cracks are found, discard the wheel.
  - **ALL** wheels with bent rim flanges must not be repaired or refinished.
  - The re-machining and the re-clear coating of aluminum wheels is not recommended in the dealer environment due to concerns of repair durability.
  - Do not use any re-machining process that removes aluminum. This could affect the dimensions and function of the wheel.

### **Aluminum Wheel Refinishing General Recommendations/Options**

- Painted aluminum wheels use a primer, color coat, and clearcoat procedure. If the paint is damaged, refinishing is possible. As with polished wheels, all original coatings must be removed first. Media blasting is recommended. (See option number 1).
- If the clearcoat is damaged, it is possible to refinish with clearcoat only, however, the required refinishing process cannot be performed in the dealer environment. Refer to Refinishers Responsibility (Repair option #2).
- Re-plating of chrome-plated aluminum wheels is not recommended.

### **Repair Option Number 1**

### **Material Required/Information Resources**

- The Paint Manufactures Color Book
- Refer to the latest GM Approved Refinish Materials Booklet (GM 4901 MD-2005) for specific products for aluminum refinishing.

- To access the booklet, go to [www.gmgoodwrench.com](http://www.gmgoodwrench.com). Click on GM Collision Parts. Click on GM Technical Repair Information, select Paint Shop.
- A Color Compatibility chart is also at this site defining what colors are used on what models.

**IMPORTANT: Chemical strippers are not recommended.**

- Refer to specific Paint Manufactures for refinish procedures and process pertaining to "Aluminum Refinishing".

The procedure requires the wheel surface to be plastic media blasted to remove old paint or clearcoat.

### General Color Selection

- If the wheels being painted were previously clearcoated aluminum, and a painted aluminum look is desired, using Corsican Silver WAEQ9283 for a fine "aluminum-like" look, or Sparkle Silver WA9967 for a very bright look. Body color is another option to the customer that may also be used.
- Some specific colors may be recommended on certain models (currently SSR and GTO).
- If painting wheels that were previously clearcoated aluminum, it is recommended that all four wheels and their center caps be refinished to maintain color uniformity.

### General Refinishing Procedures-Removal

1. Remove the wheels from the vehicle. The tires may remain mounted on the wheels.
2. Remove the balance weights and mark their locations on the tire.
3. Remove excess grease, etc. from the wheels with wax and grease remover.
4. Have the wheels plastic media blasted to remove the clearcoat.

**IMPORTANT: MASK OFF ALL MOUNTING SURFACES, whenever a wheel is refinished. The mounting surface and the wheel nut contact surfaces must not be painted or clearcoated. Coating these surfaces could affect the wheel nut torque.**

5. Clean and mask and paint the wheels.

### General Refinishing Procedures-Installation

1. Unmask the wheels.
2. Clean all wheel mounting surface of any corrosion, overspray, or dirt.

**IMPORTANT: When re-balancing a tire on an aluminum wheel, coated balance weights must be used in order to reduce the chance of future cosmetic damage.**

3. Install NEW coated balance weights at marked locations.

**IMPORTANT: Use a torque stick on an impact wrench, or a torque wrench to consistently and uniformly fasten the wheel to the specified torque for the vehicle. The star pattern must be followed.**

4. Install wheels on vehicle.

#### **Repair Option Number 2. Outside Companies**

- Some outside companies are offering wheel refinishing services. One such company, Transwheel Corporation (800-892-3733), provides this service with GM guidelines. Other companies may also exist.
- Any process that re-machines or otherwise remanufactures the wheel should not be used.
- The wheel ID must be recorded and follow the wheel throughout the process to assure that the same wheel is returned. The refinisher must permanently ID stamp the wheel and warrant the painted/clearcoated surfaces for a minimum of one year or the remainder of the new vehicle warranty, whichever is longer.
- Paint and/or clearcoat must not be present on the following surfaces: the nut chamfers, the wheel mounting surfaces and the wheel pilot hole.
- A refinishers responsibility includes inspecting for cracks using the Zyglo system or the equivalent. Any cracked wheels must not be refinished. No welding, hammering or reforming of any kind is allowed. A plastic media blast may be used for clean up of the wheel. Hand and/or lathe sanding of the machined surface and the wheel window is allowed. Material removal, though, must be kept to a minimum.

#### **TIRE AND WHEEL REMOVAL AND INSTALLATION**

**CAUTION: If penetrating oil gets on the vertical surfaces between the wheel and the rotor or drum it could cause the wheel to work loose as the vehicle is driven, resulting in loss of control and an injury accident.**

**NOTE: Never use heat to loosen a tight wheel. It can shorten the life of the wheel, studs, or hub and bearing assemblies. Wheel nuts must be tightened in sequence and to the specified torque to avoid bending the wheel or rotor.**

**NOTE: Improperly tightened wheel nuts can lead to brake pulsation and rotor damage. In order to avoid expensive brake repairs, evenly tighten the wheel nuts to the proper torque specification.**

**IMPORTANT: Removing wheels can be difficult because of foreign material or a tight fit between the wheel center hole and the hub or rotor. Excessive force, such as hammering on the wheel or tire, can cause damage. Slightly tapping the tire side wall with a rubber mallet is acceptable.**

#### **Tools Required**

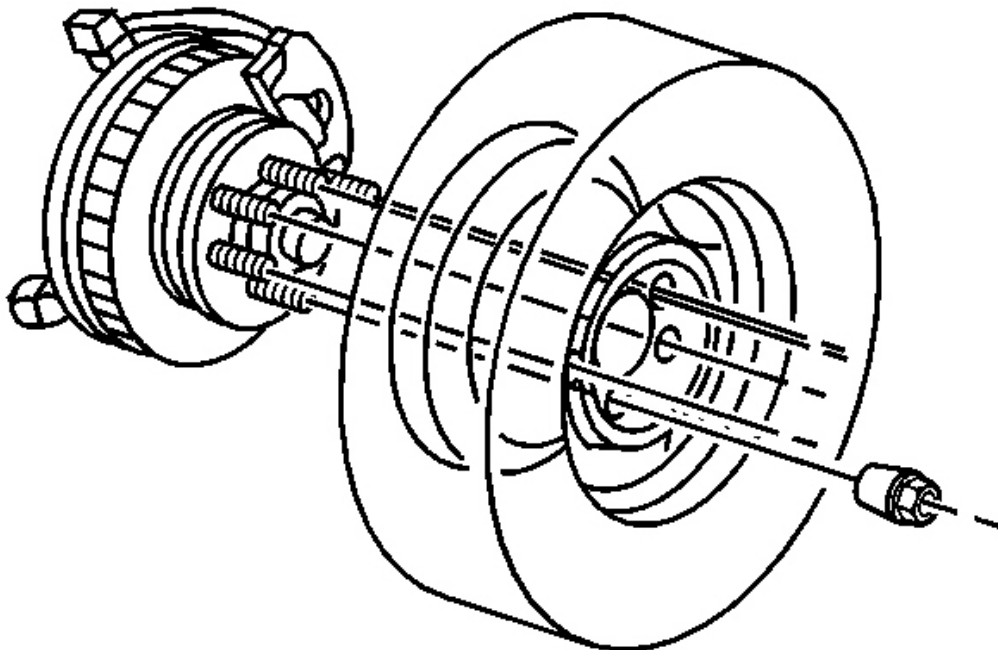
J 39544-KIT Complete Torque Socket Set

## Tire and Wheel Removal and Installation

1. Tighten all wheel nuts on the affected wheel.
2. Loosen each wheel nut two turns.
3. Rock the vehicle from side to side in order to loosen the wheel. If this does not loosen the wheel, rock the vehicle front to back applying quick hard jabs to the brake pedal to loosen the wheel.
4. Repeat this procedure if the wheel does not break free.

### Removal Procedure

1. Raise the vehicle. Support the vehicle with suitable safety stands. Refer to **Lifting and Jacking the Vehicle** in General Information.
2. Remove the wheel center cap.



**Fig. 6: View Of Tire & Wheel Assembly**  
Courtesy of GENERAL MOTORS CORP.

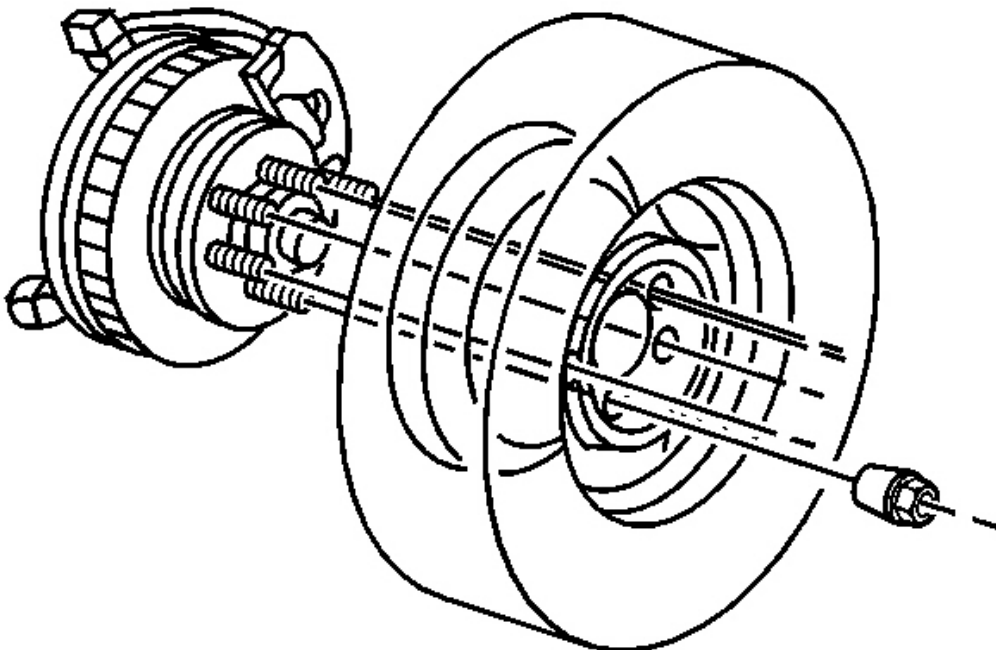
3. Remove the wheel nuts from the tire and wheel.
4. Mark the location of the tire and wheel to the hub assembly.
5. Remove the tire and wheel from the vehicle.

- Clean the wheel nuts, studs and the wheel and rotor mounting surfaces.

#### Installation Procedure

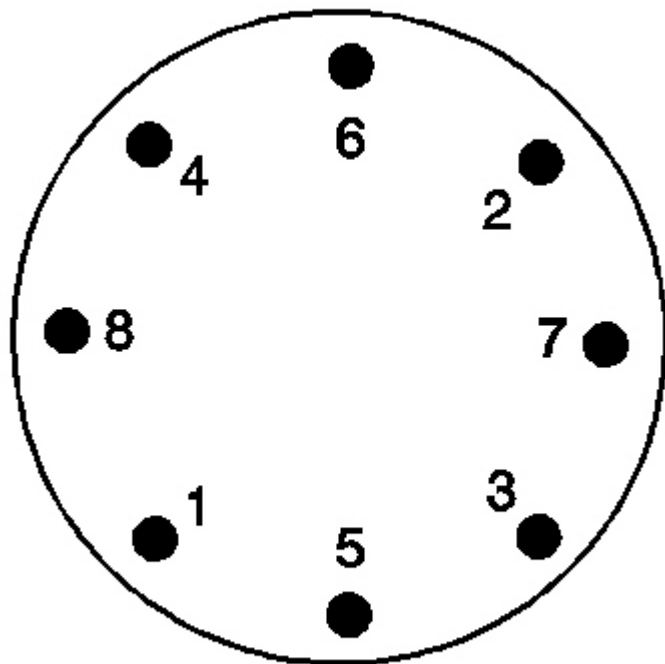
**CAUTION:** Before installing the wheels, remove any buildup of corrosion on the wheel mounting surface and brake drum or disc mounting surface by scraping and wire brushing. Installing wheels with poor metal-to-metal contact at the mounting surfaces can cause wheel nuts to loosen. This can cause a wheel to come off when the vehicle is moving, causing loss of control and possibly personal injury.

**NOTE:** A torque wrench or J 39544 must be used to ensure that wheel nuts are tightened to specification. Never use lubricants or penetrating fluids on wheel stud, nuts, or mounting surfaces, as this can raise the actual torque on the nut without a corresponding torque reading on the torque wrench. Wheel nuts, studs, and mounting surfaces must be clean and dry. Failure to follow these instructions could result in wheel, nut, and/or stud damage.



**Fig. 7: View Of Tire & Wheel Assembly**  
Courtesy of GENERAL MOTORS CORP.

1. Install the tire and wheel. Align the locating mark of the tire and wheel to the hub.



**Fig. 8: Installing Wheel Nuts**

Courtesy of GENERAL MOTORS CORP.

**NOTE:** Refer to Fastener Notice in Cautions and Notices.

**IMPORTANT:** Tighten the nuts evenly and alternately in order to avoid excessive runout.

2. Install the wheel nuts.

**Tighten:** Tighten the wheel nuts as shown to 190 N.m (140 lb ft).

3. Install the wheel center cap.
4. Remove the safety stands.
5. Lower the vehicle.

Many different materials and techniques are available on the market in order to repair tires. Not all of the materials and techniques work on some types of tires. Tire manufacturers have published detailed instructions on how and when to repair tires. Obtain the instructions from the manufacturer. If the vehicle is equipped with a compact spare tire, do not repair the compact spare.

## **TIRE MOUNTING AND DISMOUNTING**

**NOTE:** Use a tire changing machine in order to dismount tires. Do not use hand tools or tire irons alone in order to remove the tire from the wheel. Damage to the tire beads or the wheel rim could result.

**NOTE:** Do not scratch or damage the clear coating on aluminum wheels with the tire changing equipment. Scratching the clear coating could cause the aluminum wheel to corrode and the clear coating to peel from the wheel.

**NOTE:** Damage to either the tire bead or the wheel mounting holes can result from the use of improper wheel attachment or tire mounting procedures. It takes up to 70 seconds for all of the air to completely exhaust from a large tire. Failure to follow the proper procedures could cause the tire changer to put enough force on the tire to bend the wheel at the mounting surface. Such damage may result in vibration and/or shimmy, and under severe usage lead to wheel cracking.

1. Deflate the tire completely.

**IMPORTANT:** Rim-clamp, sometimes called-European-type tire changers are recommended.

2. Use the tire changer in order to remove the tire from the wheel.
3. Use a wire brush or coarse steel wool in order to remove any rubber, light rust or corrosion from the wheel bead seats.

**NOTE:** When mounting the tires, use an approved tire mounting lubricant. **DO NOT** use silicon or corrosive base compounds to lubricate the tire bead and the wheel rim. A silicon base compound can cause the tire to slip on the rim. A corrosive type compound can cause tire or rim deterioration.

4. Apply GM P/N 12345884 (Canadian P/N 5728223) or equivalent to the tire bead and the wheel rim.
5. Use the tire changer in order to install the tire to the wheel.

**CAUTION:** To avoid serious personal injury, do not stand over tire when inflating. The bead may break when the bead snaps over the safety hump. Do not exceed 275 kPa (40 psi) pressure when inflating any tire if beads are not seated. If 275 kPa (40 psi) pressure will not seat

**the beads, deflate, relubricate the beads and reinflate. Overinflation may cause the bead to break and cause serious personal injury.**

6. Inflate the tire to the proper air pressure.
7. Ensure that the locating rings are visible on both sides of the tire in order to verify that the tire bead is fully seated on the wheel.

## **TIRE ROTATION**

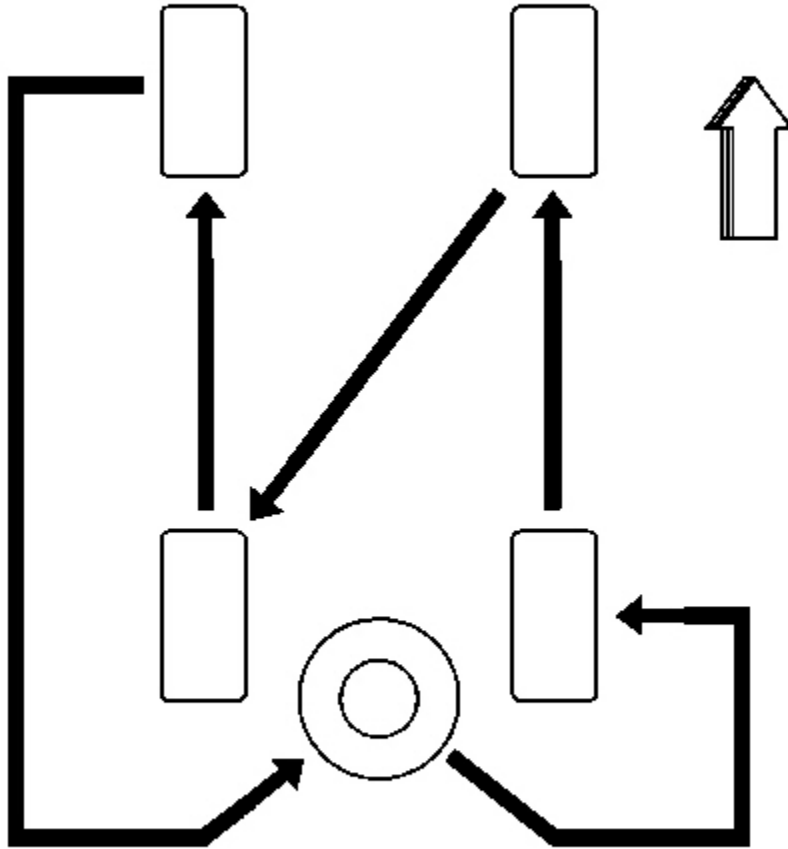
### **Removal Procedure**

In order to equalize wear, rotate the tires at the specified intervals. Refer to **Scheduled Maintenance** in Maintenance and Lubrication. In addition to scheduled rotation, rotate the tire and wheel assembly whenever you notice uneven tire wear.

Radial tires tend to wear faster in the shoulder area, particularly in front positions, due to design. Radial tires in non-drive locations may develop an irregular wear pattern that can generate tire noise. This especially makes regular tire rotation necessary.

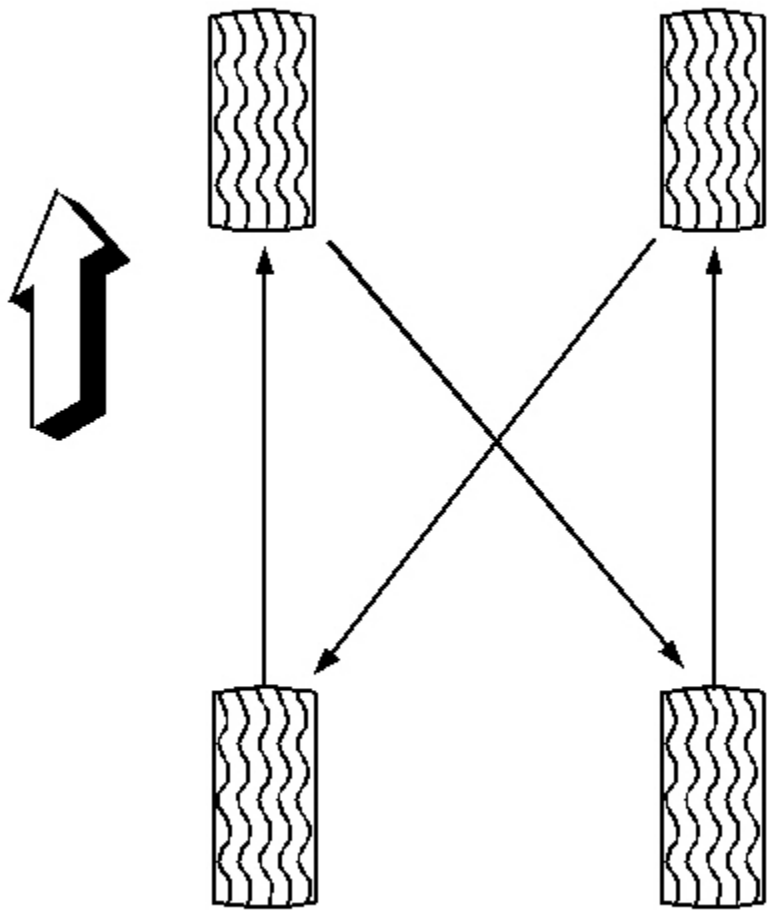
1. If the spare tire is to be included in the rotation, remove it from the vehicle.
2. Raise and support the vehicle. Refer to **Lifting and Jacking the Vehicle** in General Information.
3. Remove the 4 center caps from the wheels.
4. Remove the lug nuts from all of the 4 wheels.





**Fig. 9: Rotating Tires (5 Tires)**  
Courtesy of GENERAL MOTORS CORP.

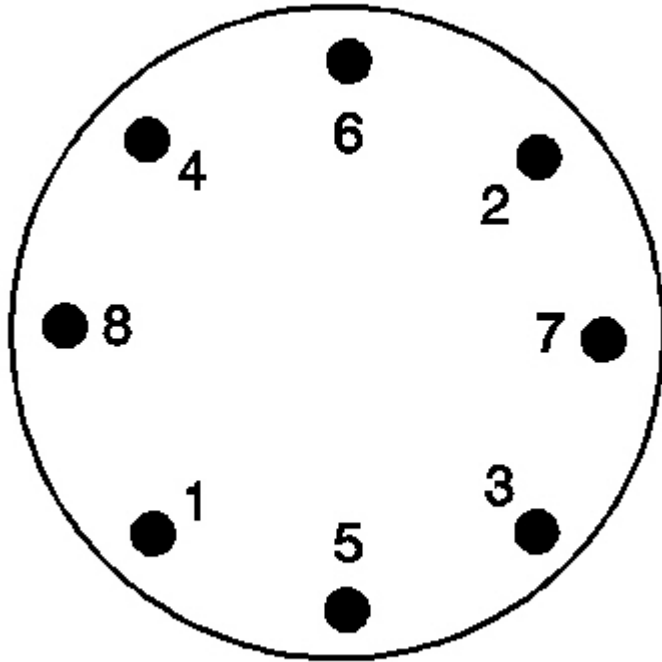
5. Including the spare tire, rotate the 5 tires as shown.



**Fig. 10: Rotating Tires (4 Tires)**  
Courtesy of GENERAL MOTORS CORP.

6. Excluding the spare tire, rotate the 4 tires as shown.

**Installation Procedure**



**Fig. 11: Installing Wheel Nuts**  
Courtesy of GENERAL MOTORS CORP.

**NOTE:** Refer to Fastener Notice in Cautions and Notices.

1. Install the lug nuts. Tighten each wheel in the sequence shown.

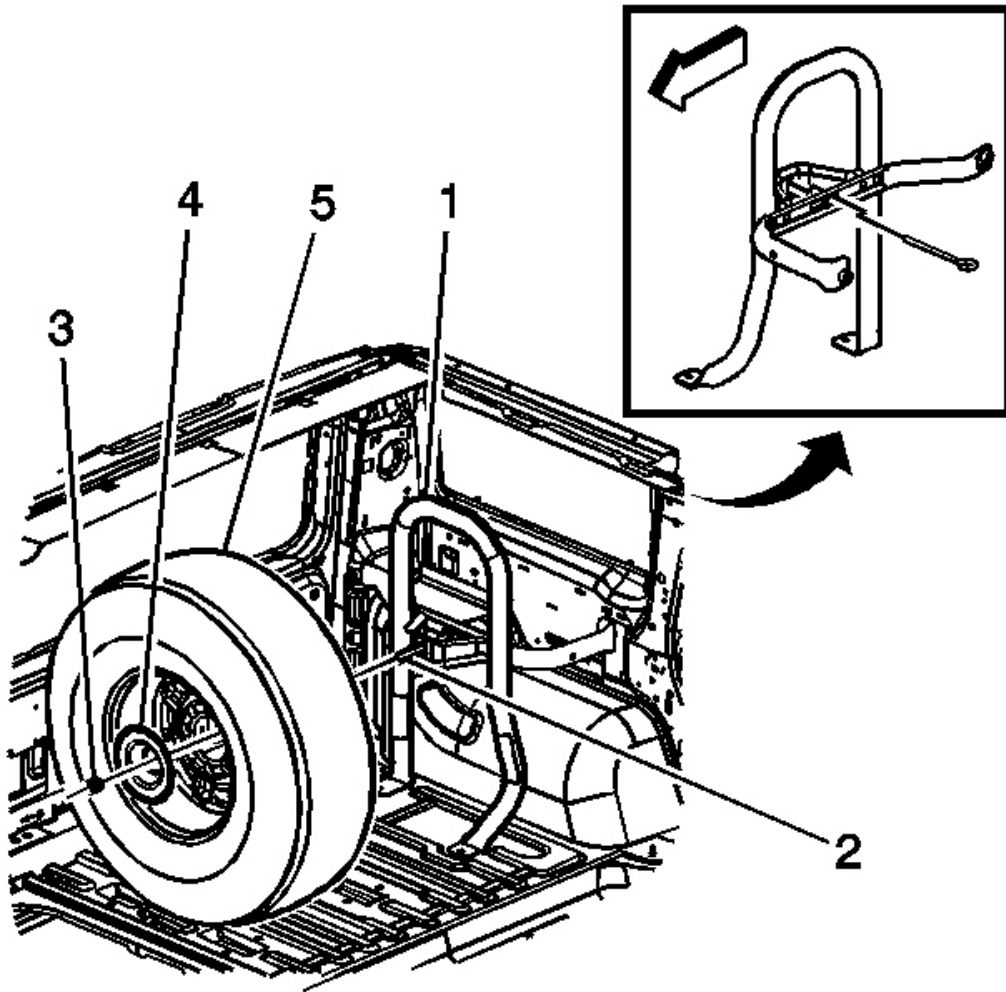
**Tighten:** Tighten the lug nuts to 190 N.m (140 lb ft).

2. Install the 4 center caps.
3. Lower the vehicle.

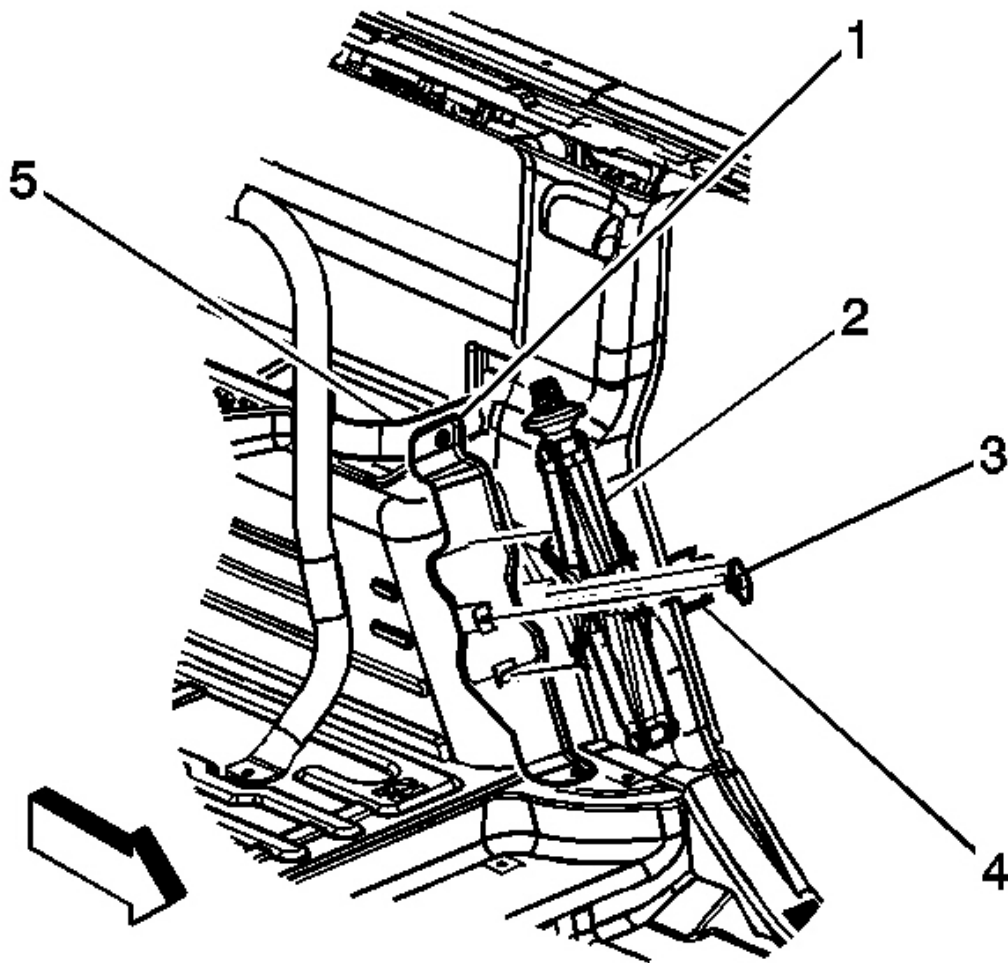
## SPARE TIRE CARRIER REPLACEMENT

### Removal Procedure

1. Remove the spare tire cover.
2. Remove the spare tire mounting nut (3), washer, and mounting plate (4).
3. Remove the spare tire (5) from the spare tire carrier (1).

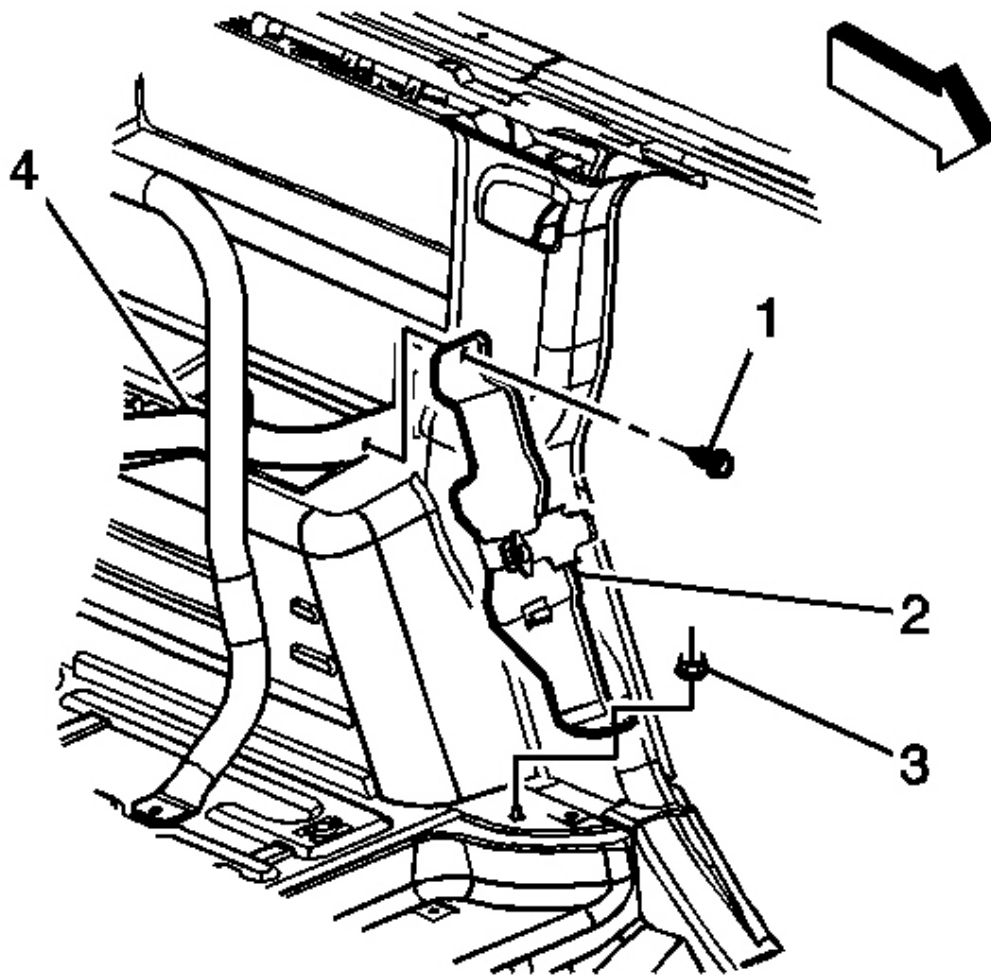


**Fig. 12: Spare Tire & Spare Tire Carrier**  
Courtesy of GENERAL MOTORS CORP.



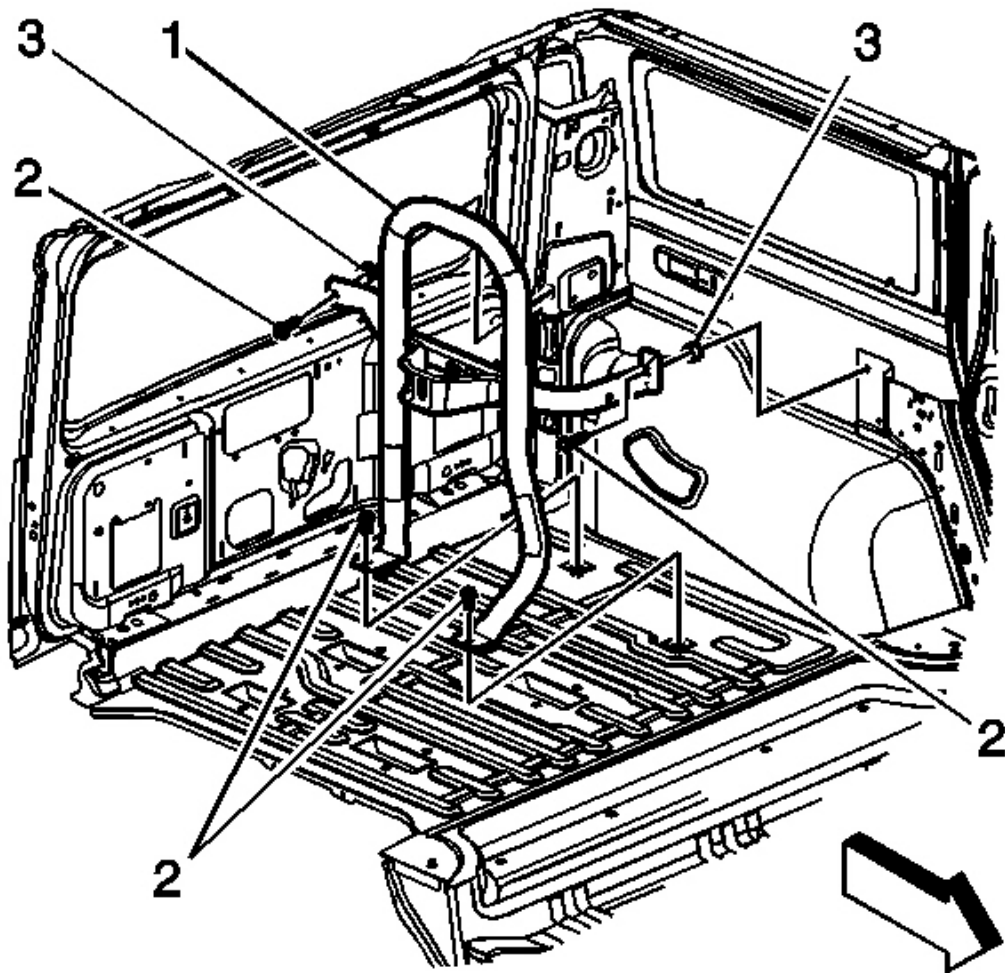
**Fig. 13: Jack & Jack Stowage Bracket Assembly**  
Courtesy of GENERAL MOTORS CORP.

4. Remove the jack retainer nut (3) and bracket (4).
5. Remove the jack (2) from the jack stowage bracket assembly (1).



**Fig. 14: Screw Securing Jack Stowage Bracket Assembly To Spare Tire Carrier**  
Courtesy of GENERAL MOTORS CORP.

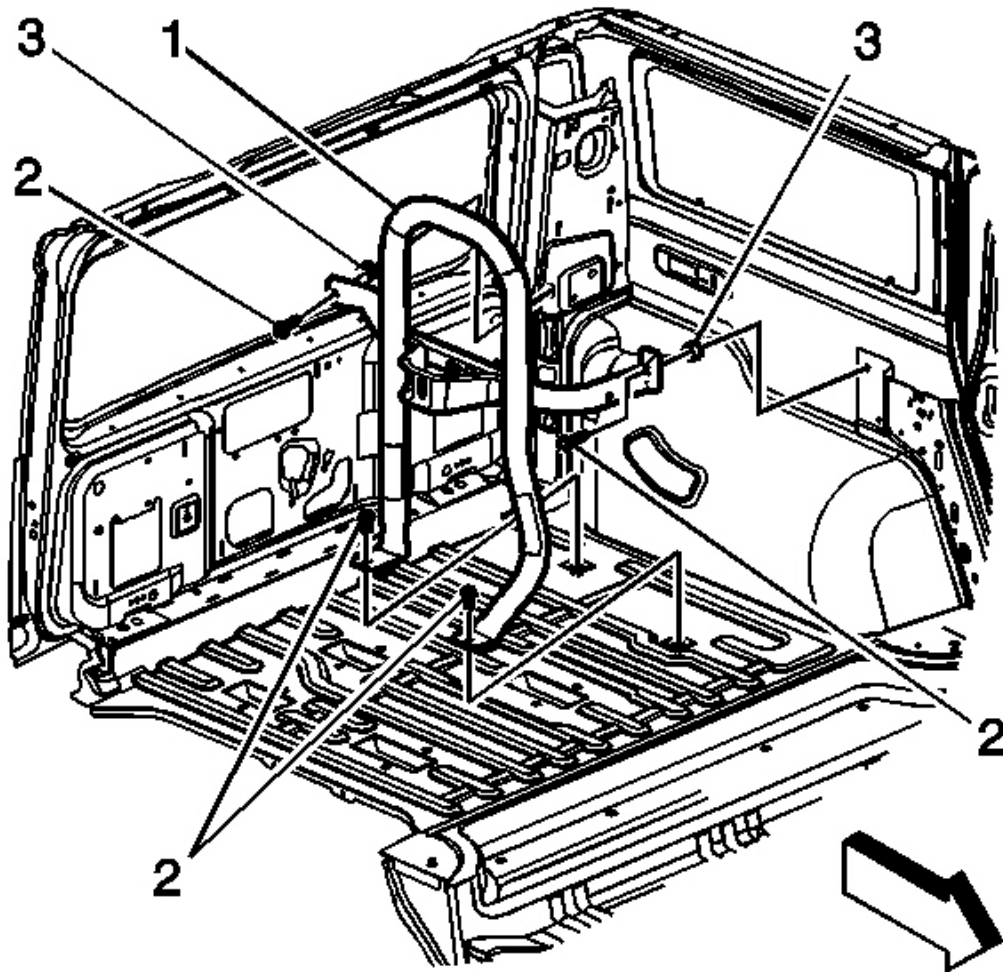
6. Remove the screw (1) securing the jack stowage bracket assembly (2) to the spare tire carrier (4).



**Fig. 15: Spare Tire Carrier**  
Courtesy of GENERAL MOTORS CORP.

7. Remove the spare tire carrier mounting bolts (2) and spacers (3).
8. Remove the spare tire carrier (1) from the vehicle.

**Installation Procedure**



**Fig. 16: Spare Tire Carrier**  
Courtesy of GENERAL MOTORS CORP.

1. Install the spare tire carrier (1) to the vehicle.

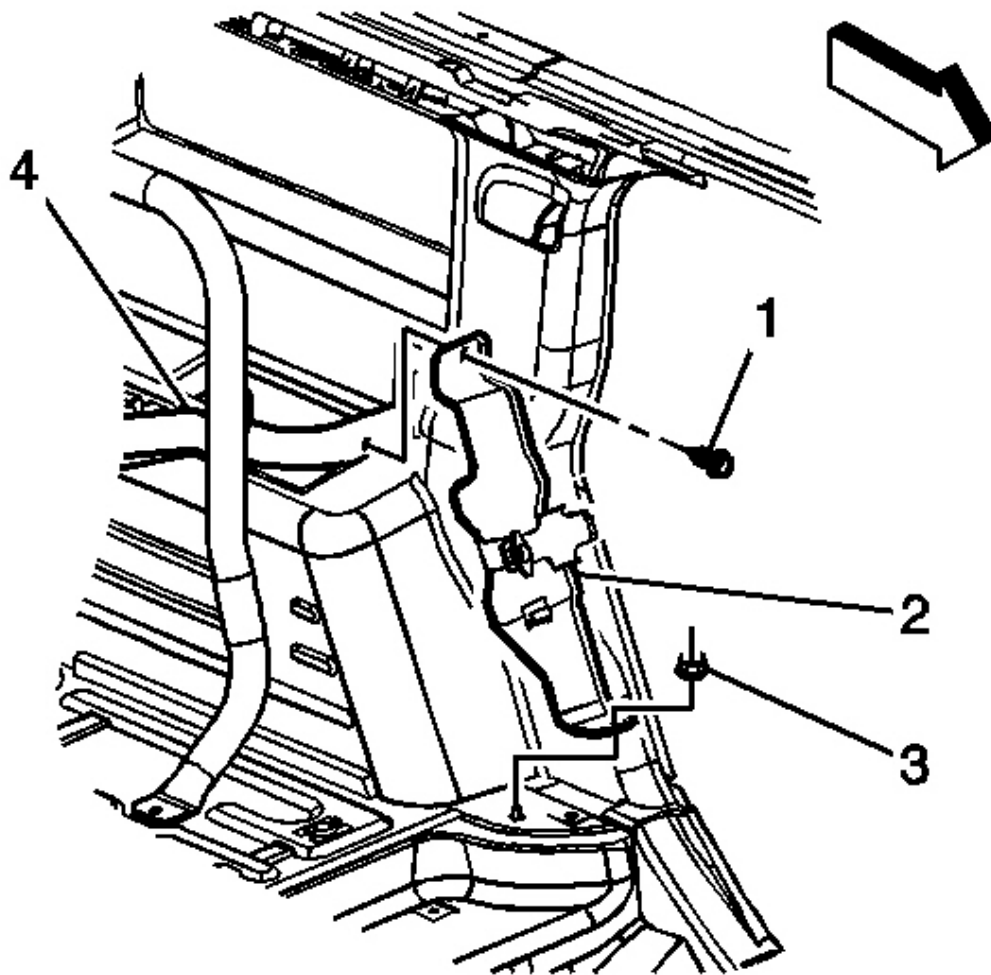
**NOTE:** Refer to Fastener Notice in Cautions and Notices.

2. Install spacers (3) and the spare tire carrier mounting bolts (2).

**Tighten:** Tighten the spare tire carrier mounting bolts to 85 N.m (63 lb ft).

**NOTE:** Refer to Fastener Notice in Cautions and Notices.

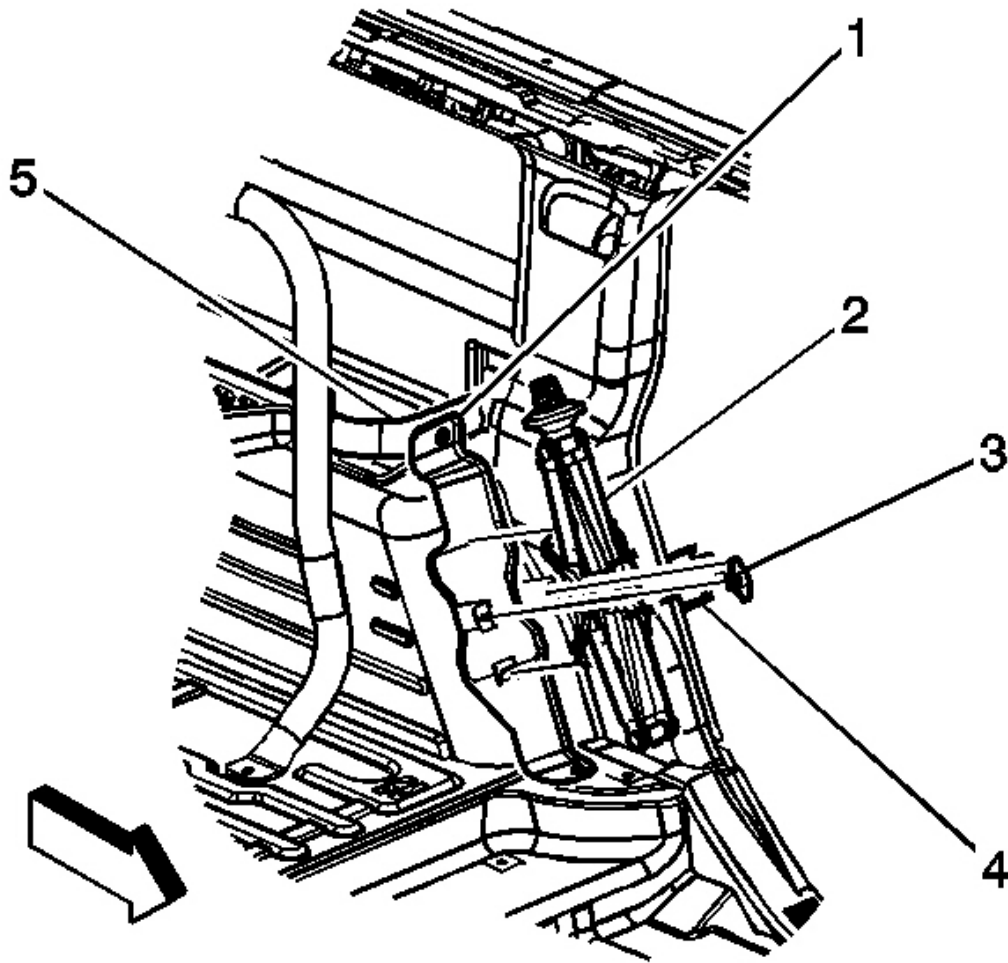




**Fig. 17: Screw Securing Jack Stowage Bracket Assembly To Spare Tire Carrier**  
Courtesy of GENERAL MOTORS CORP.

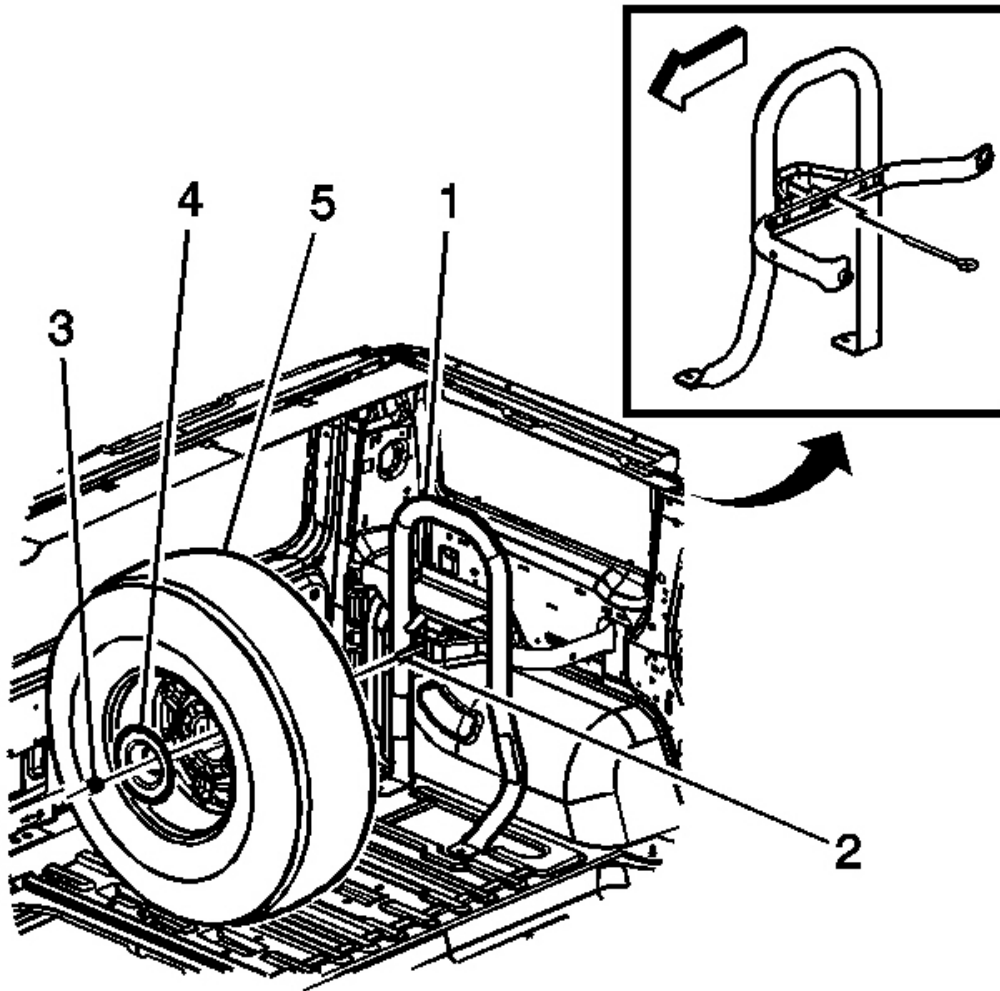
3. Install the screw (1) securing the jack stowage bracket assembly (2) to the spare tire carrier (4).

**Tighten:** Tighten the screw to 25 N.m (18 lb ft).



**Fig. 18: Jack & Jack Stowage Bracket Assembly**  
Courtesy of GENERAL MOTORS CORP.

4. Install the jack (2) to the jack stowage bracket assembly (1).
5. Install the jack bracket (4) and the nut (3).
6. Raise the jack after it is installed in the bracket to ensure that it is secure.



**Fig. 19: Spare Tire & Spare Tire Carrier**  
Courtesy of GENERAL MOTORS CORP.

7. Install the spare tire (5) to the spare tire carrier (1), inserting the stud (2) through the center of the spare tire.
8. Install the mounting plate (4), washer, and mounting nut (3).

**Tighten:** Tighten the spare tire mounting nut to 85 N.m (63 lb ft).

9. Install the spare tire cover.

## DESCRIPTION AND OPERATION

## **GENERAL DESCRIPTION**

The factory installed tires are designed to operate satisfactorily with loads up to and including the full rated load capacity when these tires are inflated to the recommended pressures.

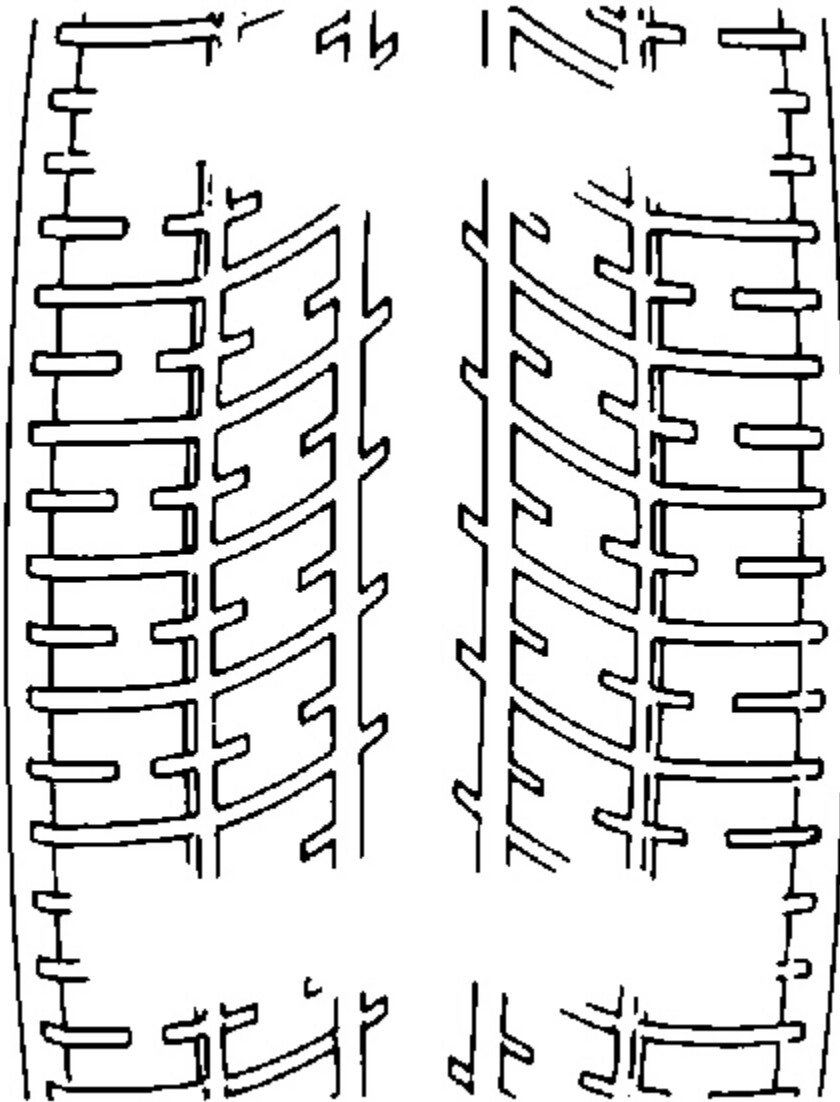
The following factors have an important influence on tire life:

- Correct tire pressures
- Correct wheel alignment
- Proper driving techniques
- Tire rotation

The following factors increase tire wear:

- Heavy cornering
- Excessively rapid acceleration
- Heavy braking

## **TREAD WEAR INDICATORS DESCRIPTION**



**Fig. 20: Tread Wear Indicators**  
Courtesy of GENERAL MOTORS CORP.

The original equipment tires have tread wear indicators that show when you should replace the tires.

The location of these indicators are at 72 degree intervals around the outer diameter of the tire. The indicators appear as a 6 mm (0.25 in) wide band when the tire tread depth becomes 1.6 mm (2/32 in).

## METRIC WHEEL NUTS AND BOLTS DESCRIPTION

Metric wheel/nuts and bolts are identified in the following way:

- The wheel/nut has the word Metric stamped on the face.
- The letter M is stamped on the end of the wheel bolt.

The thread sizes of metric wheel/nuts and the bolts are indicated by the following example: M12 x 1.5.

- M = Metric
- 12 = Diameter in millimeters
- 1.5 = Millimeters gap per thread

## TIRE INFLATION DESCRIPTION

When you inflate the tires to the recommended inflation pressures, the factory-installed wheels and tires are designed in order to handle loads to the tire's rated load capacity. Incorrect tire pressures, or under-inflated tires, can cause the following conditions:

- Vehicle handling concerns
- Poor fuel economy
- Shortened tire life
- Tire overloading

Inspect the tire pressure when the following conditions apply:

- The vehicle has been sitting at least 3 hours.
- The vehicle has not been driven for more than 1.6 km (1 mi).
- The tires are cool.

Inspect the tires monthly or before any extended trip. Adjust the tire pressure to the specifications on the tire label. Install the valve caps or the extensions on the valves. The caps or the extensions keep out dust and water.

The kilopascal (kPa) is the metric term for pressure. The tire pressure may be printed in both kilopascal (kPa) and psi. One psi equals 6.9 kPa.

### Inflation Pressure Conversion (Kilopascals to PSI)

kPa	psi	kPa	psi
140	20	215	31
145	21	220	32
155	22	230	33
160	23	235	34
165	24	240	35

170	25	250	36
180	26	275	40
185	27	310	45
190	28	345	50
200	29	380	55
205	30	415	60
Conversion: 6.9 kPa = 1 psi			

Tires with a higher than recommended pressure can cause the following conditions:

- A hard ride
- Tire bruising
- Rapid tread wear at the center of the tire

Tires with a lower than recommended pressure can cause the following conditions:

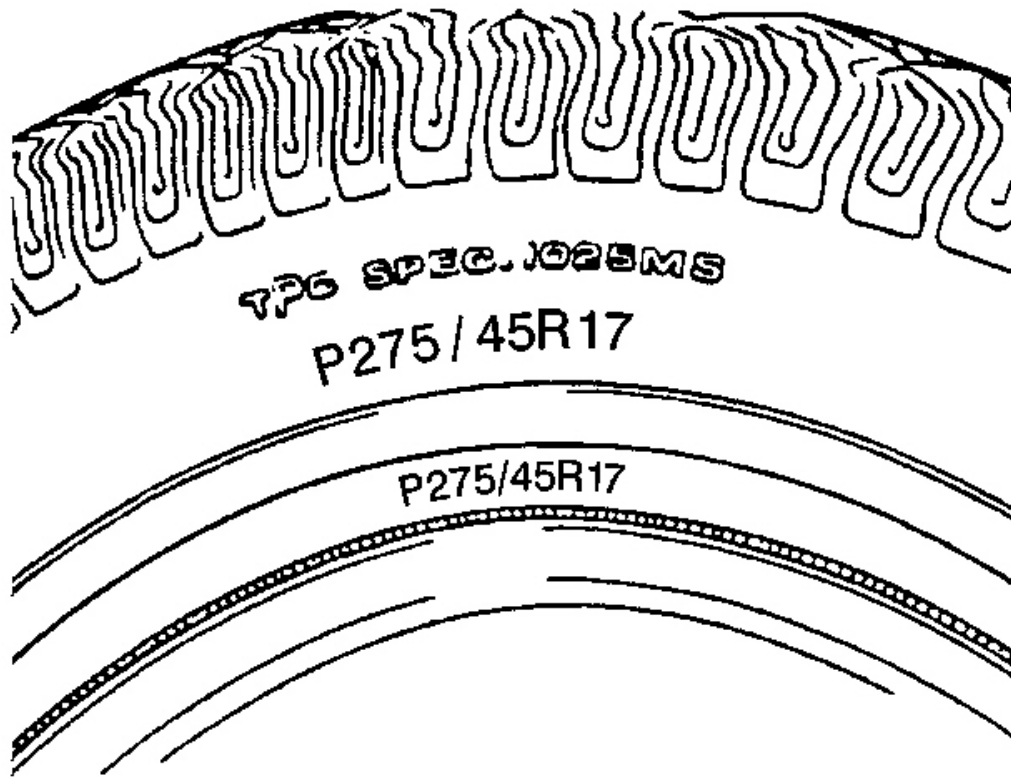
- A tire squeal on turns
- Hard steering
- Rapid wear and uneven wear on the edge of the tread
- Tire rim bruises and tire rim rupture
- Tire cord breakage
- High tire temperatures
- Reduced vehicle handling
- High fuel consumption
- Soft riding

Unequal pressure on the same axle can cause the following conditions:

- Uneven braking
- Steering lead
- Reduced vehicle handling

Refer to the Tire Placard for specific tire and wheel applications and tire pressures.

## **ALL SEASONS TIRES DESCRIPTION**



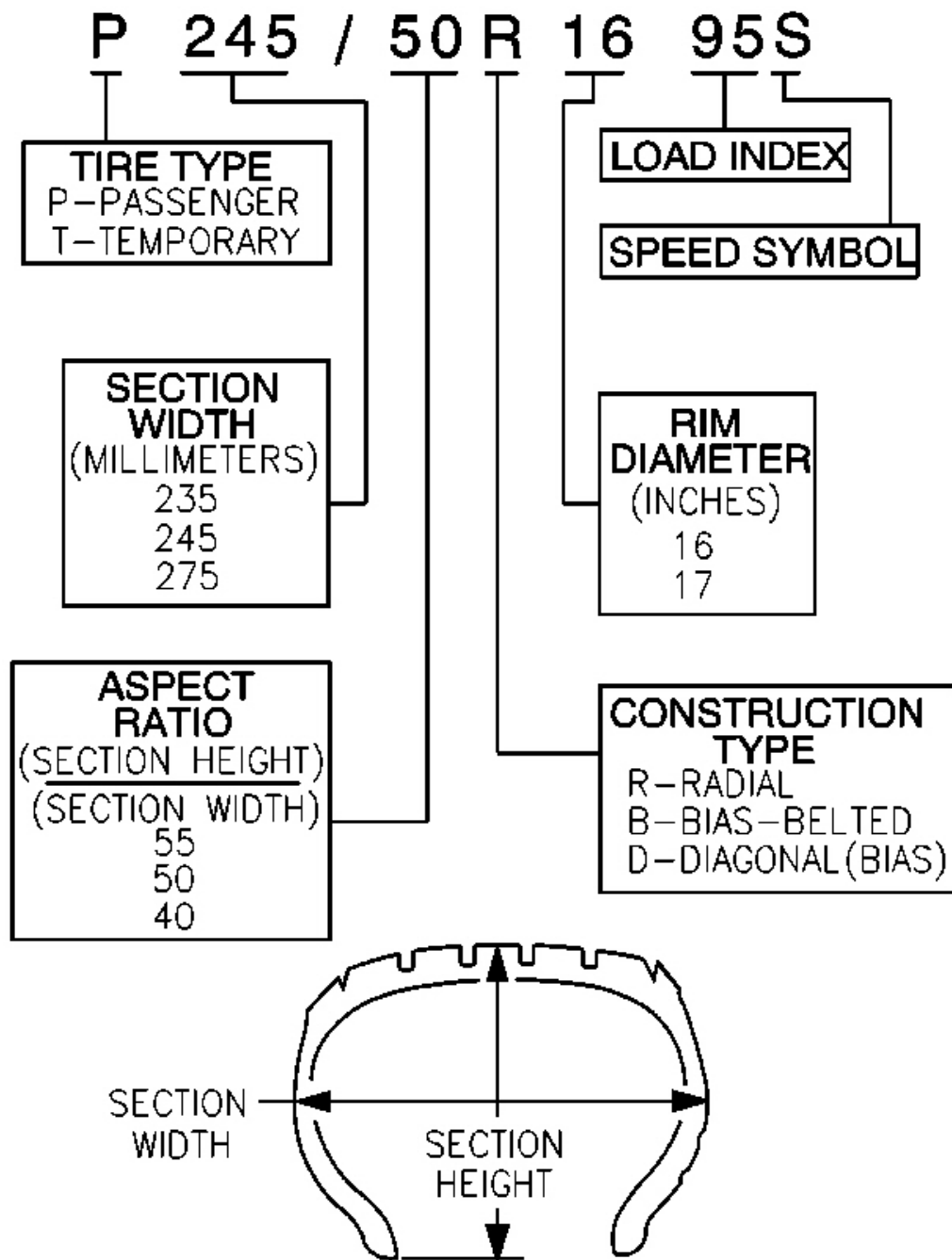
**Fig. 21: Identifying All Seasons Tires**  
Courtesy of GENERAL MOTORS CORP.

Most GM vehicles are equipped with steel belted all-season radial tires as standard equipment. These tires qualify as snow tires, with a higher than average rating for snow traction than the non-all season radial tires previously used. Other performance areas, such as wet traction, rolling resistance, tread life, and air retention, are also improved. This is done by improvements in both tread design and tread compounds. These tires are identified by an M + S molded in the tire side wall after the tire size. The suffix MS is also molded in the tire side wall after the TPC specification number.

The optional handling tires used on some vehicles now also have the MS marking after the tire size and the TPC specification number.

#### **P-METRIC SIZED TIRES DESCRIPTION**





**Fig. 22: P-Metric Sized Tire Marking**  
Courtesy of GENERAL MOTORS CORP.

Most P-metric tire sizes do not have exact corresponding alphanumeric tire sizes. Replacement tires should be of the same tire performance criteria (TPC) specification number including the same size, the same load range, and the same construction as those originally installed on the vehicle. Consult a tire dealer if you must replace the P-metric tire with other sizes. Tire companies can best recommend the closest match of alphanumeric to P-metric sizes within their own tire lines.

## **REPLACEMENT WHEELS DESCRIPTION**

Replace the wheel if any of the following conditions exist:

- The wheel exhibits excessive runout.
- The wheel is bent.
- The wheel is cracked.
- The wheel is severely rusted.
- The wheel is severely corroded.

**IMPORTANT: Air leaks caused by porosity on aluminum wheels are repairable.**

**CAUTION: If you are replacing the wheel(s), the wheel stud(s), the wheel nut(s) or the wheel bolt(s), install only new GM original equipment parts. Installation of used parts or non-GM original equipment parts may cause the wheel to loosen, loss of tire air pressure, poor vehicle handling and loss of vehicle control resulting in personal injury.**

- The wheel leaks air.

**NOTE: The use of non-GM original equipment wheels may cause:**

- **Damage to the wheel bearing, the wheel fasteners and the wheel**
- **Tire damage caused by the modified clearance to the adjacent vehicle components**
- **Adverse vehicle steering stability caused by the modified scrub radius**
- **Damage to the vehicle caused by the modified ground clearance**
- **Speedometer and odometer inaccuracy**

Replace the wheel, the wheel studs and the wheel/nuts, or the wheel bolts if applicable, if any of the following conditions exist:

- The wheel has elongated bolt holes.
- The wheel/nuts, or bolts if applicable, loosen repeatedly.


Steel wheel identification is stamped into the wheel near the valve stem.

Aluminum wheel identification is cast into the inboard side of the wheel.

## SPECIAL TOOLS AND EQUIPMENT

### SPECIAL TOOLS

#### Special Tools

Illustration	Tool Number/Description
	<p>J 39544-KIT Complete Torque Socket Set-10 Pieces</p>